

National Aeronautics and Space Administration

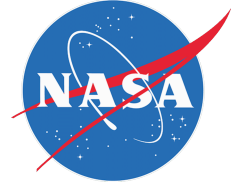

Algorithm Theoretical Basis Document (ATBD)
Version 4.4

**NASA Global Precipitation Measurement (GPM)
Integrated Multi-satellitE Retrievals for GPM
(IMERG)**

Prepared for:

**Global Precipitation Measurement (GPM)
National Aeronautics and Space Administration (NASA)**

Prepared by:

George J. Huffman
NASA/GSFC
NASA/GSFC Code 612
Greenbelt, MD 20771

and David T. Bolvin, Dan Braithwaite, Kuolin Hsu, Robert Joyce,
Pingping Xie

15 September 2014

TABLE OF CONTENTS

	<u>Page</u>
1. INTRODUCTION	1
1.1 Objective	1
1.2 Revision History	1
2. OBSERVING SYSTEMS	1
2.1 Core Satellite	2
2.2 Microwave Constellation	3
2.3 IR Constellation	4
2.4 Additional Satellites	4
2.5 Precipitation Gauges	5
3. ALGORITHM DESCRIPTION	6
3.1 Algorithm Overview	6
3.2 Processing Outline	7
3.2.1 Initial Processing	7
3.2.2 Reprocessing	9
3.2.3 Rotating Calibration Files and Spin-Up Requirements	9
3.3 Input Data	10
3.3.1 Sensor Products	10
3.3.2 Ancillary Products	10
3.4 Microwave Intercalibration	10
3.5 Merged Microwave	11
3.6 Microwave-Calibrated IR	11
3.7 Kalman-Smoother Time Interpolation	11
3.8 Satellite-Gauge Combination	12
3.9 Post-Processing	12
3.10 Precipitation Phase	13
3.11 Error Estimates	13
3.12 Algorithm Output	14
3.13 Pre-Planned Product Improvements	14
3.13.1 Addition/Deletion of Input Data	15
3.13.2 Upgrades to Input Data	15
3.13.3 Polar Sensors	15
3.13.4 Upgrades for RT	15
3.13.5 Use of Model Estimates	16
3.14 Options for Processing	16
3.14.1 Use of Multi-Spectral Geo-Data.....	16
3.14.2 Computing Propagation from Precipitation	16
3.14.3 Incorporating Cloud Development Information.....	17
3.14.4 Use of Daily Gauges.....	17
4. TESTING	17

4.1	Algorithm Verification in the System	17
4.2	Algorithm Verification for the Different Runs.....	18
4.3	Algorithm Validation	18
5.	PRACTICAL CONSIDERATIONS	18
5.1	Module Dependencies	18
5.2	Files Used in IMERG	19
5.3	Built-In Quality Assurance and Diagnostics	19
5.4	Surface Temperature, Relative Humidity, and Pressure Data.....	20
5.5	Exception Handling	21
5.6	Transitioning from TRMM- to GPM-Based Products	22
5.7	Timing of Reprocessing for Research Product	22
6.	ASSUMPTIONS AND LIMITATIONS	22
6.1	Data Delivery	22
6.2	Assumed Sensor Performance	23
7.	REFERENCES	23
8.	ACRONYMS	24

LIST OF FIGURES

	<u>Page</u>
Figure 1 PMW sensor overpass times for 12-24 Local Time (LT; 00-12 LT is the same) for the modern PMW sensor era. Shading indicates that the precessing TRMM and GPM cover all times of day.	4
Figure 2. High-level block diagram illustrating the major processing modules and data flows in IMERG. The blocks are organized by institution to indicate heritage, but the final code package will be an integrated system. The numbers on the blocks are for reference in Section 5. Box 3 is computed at CPC as an integral part of IMERG.	8

LIST OF TABLES

	<u>Page</u>
Table 1. List of likely contributing data sets for IMERG, broken out by sensor type. Data sets with start dates of Jan 98 extend before that time, but these data are not relevant to IMERG. Square brackets ([]) indicate an estimated date. “M-T” stands for Megha-Tropiques. <i>The M-T MADRAS instrument is not included on this list because of its short, gappy record.</i> It is planned that the geosynchronous IR data will be processed into “even-odd” files at NESDIS. All “Precip” is Level 2 (scan/pixel) except for the precipitation gauge analyses.	2-3

Table 2. Notional requirements for IMERG. TCI and GCI are TRMM Combined Instrument and GPM Combined Instrument, respectively.	7
Table 3. Lists of data fields to be included in each of the output datasets.	14
Table 4. Estimates of file counts and sizes to be used in IMERG. The letters i, o, t, a, s in “Module Relation” indicate input, output, transfer (between modules or within a module), accumulator, and static, respectively. The numbers in “Module Relation” are keyed to the numbered boxes in Fig. 2.	20-21

1. INTRODUCTION

1.1 OBJECTIVE

This document describes the algorithm and processing sequence for the Integrated Multi-satellite Retrievals for GPM (IMERG). This algorithm is intended to intercalibrate, merge, and interpolate “all” satellite microwave precipitation estimates, together with microwave-calibrated infrared (IR) satellite estimates, precipitation gauge analyses, and potentially other precipitation estimators at fine time and space scales for the TRMM and GPM eras over the entire globe. The system is run several times for each observation time, first giving a quick estimate and successively providing better estimates as more data arrive. The final step uses monthly gauge data to create research-level products. Background information and references are provided to describe the context and the relation to other similar missions. Issues involved in understanding the accuracies obtained from the calculations are discussed. Throughout, a baseline Day-1 product is described, together with options and planned improvements that might be instituted after launch depending on maturity and project constraints.

1.2 REVISION HISTORY

<i>Version</i>	<i>Date</i>	<i>Author</i>	<i>Description</i>
1.0	30 November 2010	G. Huffman	Initial version
2.0	30 November 2011	G. Huffman	Second delivery version
3.0	30 November 2012	G. Huffman	Third delivery version
3.1	12 July 2013	G. Huffman	Document Prob. Liq. Precip. Type
4	30 September 2013	G. Huffman	Fourth delivery version
4.1	16 December 2013	G. Huffman	At-launch modifications
4.2	20 December 2013	G. Huffman	Edits; add overpass diagram
4.3	22 July 2014	G. Huffman	Edits for post-launch information
4.4	15 September 2014	G. Huffman	Change to single snapshot each half hour

2. OBSERVING SYSTEMS

Historically and for the foreseeable future, passive microwave (PMW) sensors provide the lion’s share of relatively accurate satellite-based precipitation estimates, and these are only available from low-Earth-orbit (leo) platforms. IMERG is designed to compensate for the limited sampling available from single leo-satellites by using as many leo-satellites as possible, and then filling in gaps with geosynchronous-Earth-orbit (geo) infrared (IR) estimates. This happens in two ways. First, the leo-PMW data are morphed (linear interpolation following the geo-IR-based feature motion). Second, geo-IR precipitation estimates are included using a Kalman filter when the leo-PMW are too sparse. Additionally, at high latitudes the usual PMW imager channels are not useful, but satellite-sounding-based and experimental sounding-channel-based algorithms have shown utility and numerical-model-based estimates have the potential to add value. Finally, precipitation gauge analyses are used to provide crucial regionalization and bias correction to the satellite estimates. None of the satellites except the GPM Core satellite are under GPM direction. Therefore, IMERG uses as many satellites of opportunity as possible in a very flexible framework. Table 1 gives a listing of the likely data sources, the primary parameters, the date spans of useful operation, and the responsible institution. Note that we plan

to provide a continuous record from the beginning of TRMM. In all cases except the geo-IR and the precipitation gauge analyses the input data are accessed as Level 2 (scan-pixel) precipitation.

2.1 CORE SATELLITE

The GPM Core Satellite, like the TRMM satellite before it, serves as both a calibration and an evaluation tool for all the PMW- and IR-based precipitation products integrated in IMERG, since it will provide match-ups with all other PMW-equipped leo-satellites and IR-equipped geo-satellites. Both the TRMM and GPM satellites provide multi-channel, dual-polarization PMW sensors and active scanning radars. Three critical improvements in GPM are that 1) the orbital inclination has been increased from 35° to 65°, affording coverage of important additional climate zones; 2) the radar has been upgraded to two frequencies, adding sensitivity to light precipitation; and 3) “high-frequency” channels (165.5 and 183.3 GHz) have been added to the PMW imager, which are expected to facilitate sensing of light and solid precipitation. The higher inclination for the GPM orbit reduces the radiometer and radar sampling compared to TRMM in the latitude band covered by TRMM.

Table 1. List of likely contributing data sets for IMERG, broken out by sensor type. Data sets with start dates of Jan 98 extend before that time, but these data are not relevant to IMERG. Square brackets ([]) indicate an estimated date. “M-T” stands for Megha-Tropiques. The M-T MADRAS instrument is not included on this list because of its short, gappy record. It is planned that the geosynchronous IR data will be processed into “even-odd” files at NESDIS. All data are at Level 2 (scan/pixel) except for the precipitation gauge analyses and IR data.

<i>Merged Radar – Passive Microwave Imager Products</i>	
<i>Product</i>	<i>Period of Record</i>
GPM DPR-GMI	Mar 14 - [Feb 19]
TRMM PR-TMI	Jan 98 - [Nov 14]

<i>Conically-Scanning Passive Microwave Imagers and Imager/Sounders</i>	
<i>Sensor</i>	<i>Period of Record</i>
Aqua AMSR-E	Jun 02 - Oct 11
DMSP F13 SSMI	Jan 98 - Jul 09
DMSP F14 SSMI	Jan 98 - Aug 08
DMSP F15 SSMI	Feb 00 - Aug 06
DMSP F16 SSMIS	Nov 05 - [Nov 15]
DMSP F17 SSMIS	Mar 08 - [Nov 18]
DMSP F18 SSMIS	Mar 10 - [Mar 20]
DMSP F19 SSMIS	[Jul 14] - [Jan 24]
GCOMW1 AMSR2	May 12 - [May 22]
GCOMW2 AMSR2	[Feb 16] - [Jan 26]

Table 1, continued.

<i>Cross-Track-Scanning Passive Microwave Sounders</i>	
<i>Sensor</i>	<i>Period of Record</i>
GPM GMI	Mar 14 - [Feb 19]
TRMM TMI	Jan 98 - [Dec 16]
JPSS-1 ATMS	[Jun 16] - [Jun 21]
METOP-2/A MHS	Dec 06 - [Dec 16]
METOP-1/B MHS	Aug 13 - [Aug 23]
METOP-3/C MHS	[Apr 16] - [Apr 26]
M-T SAPHIR *	[Oct 11] - [Jan 15]
NOAA-15 AMSU	Jan 00 - Sep 10
NOAA-16 AMSU	Oct 00 - Apr 10
NOAA-17 AMSU	Jun 02 - Dec 09
NOAA-18 MHS	May 05 - [Jun 15]
NOAA-19 MHS	Feb 09 - [Apr 19]
NPP ATMS	Nov 11 - [Nov 21]

* Parts of the SAPHIR record suffer drop-outs.

<i>Geosynchronous Infrared Imagers</i>			
<i>Satellite</i>	<i>Sub-sat. Lon.</i>	<i>Param</i>	<i>Agency</i>
GMS & MTSat series	140E	Tb	JMA
GOES-E series	75W	Tb	NESDIS
GOES-W series	135W	Tb	NESDIS
Meteosat prime series	0E	Tb	EUMETSAT
Meteosat repositioned series	63E	Tb	EUMETSAT

<i>IR/Passive Microwave Sounders</i>		
<i>Sensor</i>	<i>Period of Record</i>	<i>Institution</i>
Aqua AIRS	Sep 02 - [Sep 15]	NASA/GSFC DISC
NOAA-14 TOVS	Jan 98 - April 05	Colo. State Univ.; NOAA/NCDC
NPP CrIS	Nov 11 - [Nov 21]	NASA/GSFC DISC

<i>Precipitation Gauge Analyses</i>	
<i>Period of Record</i>	<i>Institution</i>
Jan 98 - ongoing	DWD/GPCC

2.2 MICROWAVE CONSTELLATION

The constellation of PMW satellites (Fig. 1) is largely composed of satellites of opportunity. That is, their orbital characteristics, operations, channel selections, and data policies are outside the control of NASA. The exception is the GPM Core satellite (and TRMM for the remainder of its useful life). The imager channels are considered best for low- and mid-latitude use, while the sounding channels maintain some skill in cold and frozen-surface conditions. Research work

with the high-frequency channels is beginning to demonstrate that the high-frequency channels on AMSU, GMI, MHS, and SSMIS are also useful at higher latitudes.

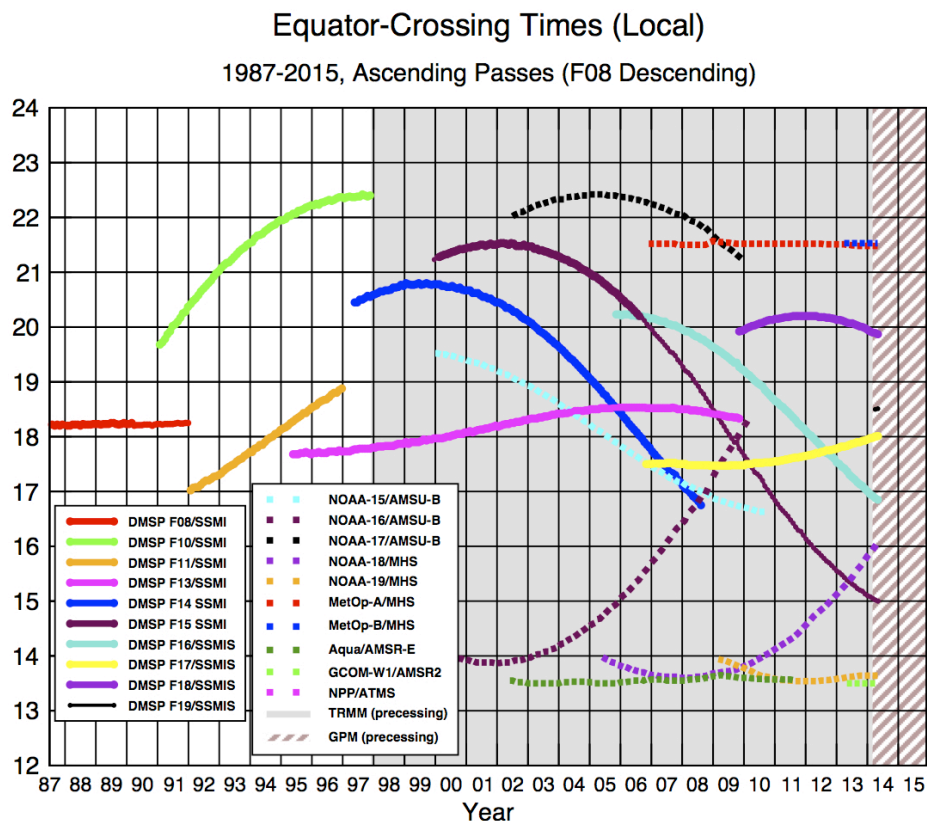

Image by Eric Nelkin (SSAI), 27 May 2014, NASA/Goddard Space Flight Center, Greenbelt, MD.

Fig. 1 PMW sensor overpass times for 12-24 Local Time (LT; 00-12 LT is the same) for the modern PMW sensor era. Shading indicates that the precessing TRMM and GPM cover all times of day.

2.3 IR CONSTELLATION

Although three different organizations control the geo-IR satellites, long-standing international agreements ensure coordination of orbits and mutual aid in the event of an unexpected satellite failure. The basic requirement is for full-disk images every three hours at the major synoptic times (00, 03, ..., 21 UTC). All satellite operators provide a great deal of imagery beyond that, although piecing it together can be somewhat challenging. These data are accessed as brightness temperatures (Tb) in the two-layer “even-odd” format developed at NOAA/CPC for CMORPH. The dataset assembly will be carried out at NOAA/CPC.

2.4 ADDITIONAL SATELLITES

Experience in creating fully global precipitation products for the Global Precipitation Climatology Project (GPCP) demonstrates that precipitation estimated from satellite soundings using the Susskind et al. (1997) algorithm has useful skill at scales as fine as 1° daily (Adler et al. 2003; Huffman et al. 1997). Even assuming that high-frequency channels on AMSU/MHS,

GMI, and SSMIS eventually provide high-quality precipitation estimates at high latitudes, we expect that the sounding-based estimates will still be needed to fill gaps in the collection of high-latitude estimates.

2.5 PRECIPITATION GAUGES

Work in GPCP and TRMM has shown that incorporating precipitation gauge data is important for controlling the bias that typifies satellite precipitation estimates. These projects show that even monthly gauge analyses produce significant improvements, at least for some regions in some seasons. Recent work at CPC shows substantial improvements in the bias correction using daily gauge analysis for regions in which there is a sufficient number of gauges. After Day-1 the use of daily gauges will be explored.

The Deutscher Wetterdienst (DWD) Global Precipitation Climatology Centre (GPCC) was established over twenty years ago to provide high-quality precipitation analyses over land based on conventional precipitation gauges. In Day-1 we expect to use two GPCC products, the Full Data Analysis for the majority of the time (currently 1998-2010), and the Monitoring Product from 2011 to the then-present.

The Monitoring Product is posted about two months after the month of observation (see Schneider et al. 2008; Rudolf and Schneider, 2005) and is based on SYNOP and monthly CLIMAT reports received in near-real time via GTS from ~7,000–8,000 stations world-wide reported in the following sources:

- monthly precipitation totals accumulated at GPCC from the SYNOP reports received at DWD, Offenbach,
- monthly precipitation totals accumulated at CPC/NOAA from the SYNOP reports received at NOAA, Washington D.C.,
- monthly precipitation totals from CLIMAT reports received at DWD, Offenbach, Germany,
- monthly precipitation totals from CLIMAT reports received at the UK Met. Office (UKMO), Exeter, UK, and
- monthly precipitation totals from CLIMAT reports received at Japan Meteorological Agency (JMA), Tokyo, Japan.

GPCC's Full Data Analysis is based on a significantly enlarged data base that covers the period 1901 up to 2010 (current V.6 released in late 2011), with an extension to incorporate important new data from China. Compared to the Monitoring Product, the Full Data Analysis includes additional data acquired from global data collections such as GHCN, FAO, CRU; data sets from the National Meteorological and/or Hydrological Services of about 190 countries of the world; and some data from GEWEX-related projects.

For both products, if data are available from more than one source for a station, an “optimum” value – according to the quality of the different data sources – is selected for the precipitation analysis. The selected precipitation data undergo an automatic pre-screening and subsequently the data flagged as questionable are interactively reviewed by an expert. Based on the remaining quality-controlled station data, the (monthly) anomalies from the background climatology are computed at the stations, interpolated using the SPHEREMAP objective analysis, and added to the background climatology to create the month's analysis.

CPC collects daily precipitation gauge data from ~16,000 stations around the world through the GTS, and from enhanced national networks over the U.S., Mexico, and a few other countries. They analyze global daily precipitation on a quasi real-time basis by interpolating quality-controlled station reports. Note that the “day” in this analysis is defined region by region, not at a uniform UTC time. These data are the basis for the daily satellite-gauge option in Subsection 3.12.4.

3. ALGORITHM DESCRIPTION

Given the available diverse, changing, uncoordinated set of input precipitation estimates, with various periods of record, regions of coverage, and sensor-specific strengths and limitations, we seek to compute the longest, most detailed record of “global” precipitation. To do this, we combine the input estimates into a “best” data set. Although we wish to maintain reasonable homogeneity in the input datasets, for example by using consistently processed archives for each sensor, we are not striving to compute a Climate Data Record dataset.

What are the requirements for the Day-1 Combined Satellite product? No formal survey has been done, but in fact a fairly firm set of notional requirements can be condensed, as summarized in Table 2. The space-time resolution is roughly the microwave spatial scale and the IR temporal scale. The space-time domain represents the PMM goal of covering the whole globe starting with TRMM. Multiple output products are specified to satisfy different classes of users, summarized in Subsection 3.2. The term “snapshot” for half-hourly estimates reflects the fact that individual satellite overpasses are the basis for these data. However, the resulting satellite estimates are not “instantaneous”, but represent an interval that can exceed an hour (Villarini et al., 2008). The best TRMM, and then GPM estimate of precipitation should be taken as the calibration standard. Currently this is considered to be the TRMM Combined Instrument (TCI, using TMI and PR) and the comparable GPM Combined Instrument (GCI, using GMI and DPR). As well, gauge data are clearly important for anchoring the satellite estimates. Error estimates and embedded auxiliary data fields are key to giving users (and developers) the information needed to assess quality by time and region over the life of the dataset. Finally, as a quasi-operational system, the code must “take a licking and keep on ticking.”

3.1 ALGORITHM OVERVIEW

A great deal of expertise in merged precipitation algorithms has been developed in the U.S. during the TRMM era, funded mainly by PMM and by NASA NEWS, NOAA programs (CPO, USWRP), NSF SAHRA, and UNESCO GWADI. In many ways the challenge in the current effort was to identify the strengths of the various groups on the PMM Science Team and merge their efforts to create a unified U.S. algorithm. Specifics are:

- Perform careful intercalibration of microwave estimates
 - the GSFC group has a strong background
- Provide finer time and space scales to get adequate sampling
 - the CPC group has strong experience with Lagrangian time interpolation using Kalman filters – CMORPH-KF
- Provide microwave-calibrated IR estimates to fill “holes” in the PMW constellation
 - the CPC group operationally produces the 4-km Merged and “Even-Odd” IR Tb products
 - the U.C.-Irvine group has strong experience in computing IR estimates

- Incorporate gauge data to control bias
 - the GSFC group has a strong background in monthly corrections
 - the CPC group has developed a test system to perform daily bias correction
- Provide error estimates
 - both the GSFC and CPC groups bring strengths
- Deliver and support a code package that runs in the PMM Precipitation Processing System (PPS) environment
 - the GSFC group has a strong track record

The high-level block diagram that results from this analysis is shown in Fig. 2, which identifies the institutions that provide the heritage code for the various blocks.

Table 2. Notional requirements for IMERG.

Resolution	0.1° [i.e., roughly the resolution of microwave estimates]
Time interval	30 min. [i.e., the geo-satellite interval]
Spatial domain	global, initially filled with data 60°N-60°S
Time domain	1998-present; later explore entire SSMI era (1987-present)
Product sequence	“Early” sat. (~4 hr), “Late” sat. (~12 hr), “Final” sat.-gauge (~2 months after month) [more data in longer-latency products]
Instantaneous vs. accumulated	Snapshot for half-hour, accumulation for monthly
Sensor precipitation products intercalibrated to TCI before GPM launch, later to GCI	
Global, monthly gauge analyses including retrospective product; explore use in submonthly-to-daily and near-real-time products	
Error estimates; final form still open for definition	
Embedded data fields showing how the estimates were computed	
Precipitation phase estimates; probability of liquid precipitation	
Operationally feasible, robust to data drop-outs and (constantly) changing constellation	
Output in HDF5 v1.8 (compatible with NetCDF4)	
Archiving and reprocessing for all RT and post-RT products	

3.2 PROCESSING OUTLINE

3.2.1 Initial Processing

The block diagram for IMERG is shown in Fig. 2. In words, the input precipitation estimates computed from the various satellite PMW sensors are assembled, mostly received as Level 2 precipitation estimates from the relevant producers, but potentially computed in a few cases at PPS as is now done for the TRMM Multi-satellite Precipitation Analysis (TMPA; Huffman et al., 2007). These estimates are gridded and intercalibrated, then combined into half-hourly fields and provided to both the CPC Morphing-Kalman Filter (CMORPH-KF; Joyce and Xie, 2011) Lagrangian time interpolation scheme and the Precipitation Estimation from Remotely Sensed Information using Artificial Neural Networks – Cloud Classification System (PERSIANN-CCS; Hong et al., 2004) re-calibration scheme. In parallel, CPC will assemble the zenith-angle-corrected, intercalibrated “even-odd” geo-IR fields and forward them to PPS for use in the

CMORPH-KF Lagrangian time interpolation scheme and the PERSIANN-CCS computation routines. The PERSIANN-CCS estimates are computed (supported by an asynchronous re-calibration cycle) and sent to the CMORPH-KF Lagrangian time interpolation scheme. The CMORPH-KF Lagrangian time interpolation (supported by an asynchronous KF weights updating cycle) uses the PMW and IR estimates to create half-hourly estimates. Note that

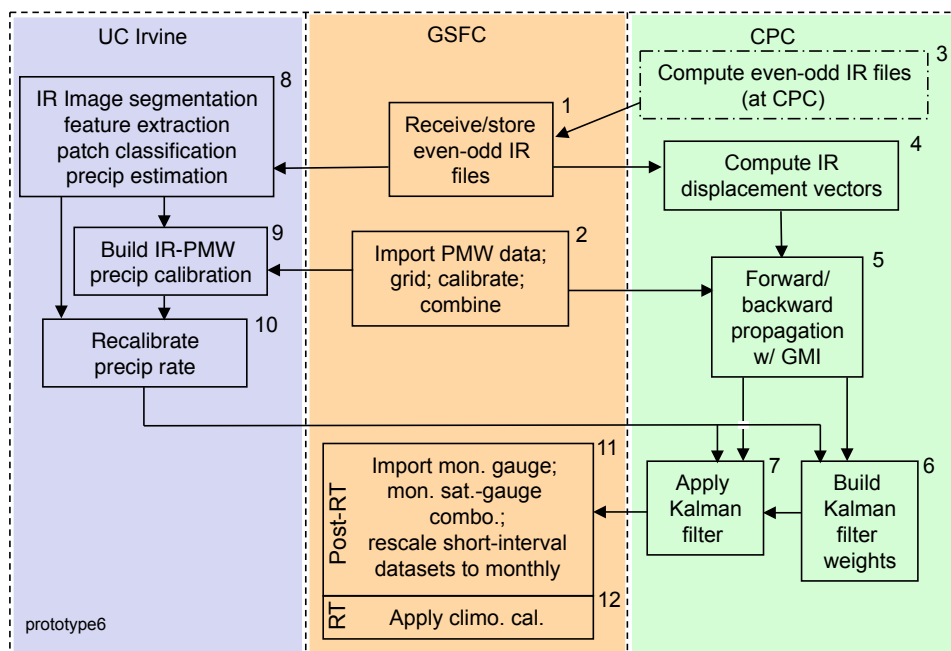

Fig. 2. High-level block diagram illustrating the major processing modules and data flows in IMERG. The blocks are organized by institution to indicate heritage, but the final code package will be an integrated system. The numbers on the blocks are for reference in Section 5. Box 3 is computed at CPC as an integral part of IMERG.

various intermediate fields will be carried through the processing as necessary to populate the fields in the output file (Table 2). Precipitation phase is computed in the microwave merger step as a diagnostic using surface type, surface temperature, and surface humidity (Section 3.9). The system will be run twice in near-real time:

- “Early” multi-satellite product ~4 hr after observation time and
- “Late” multi-satellite product ~12 hr after observation time, and once after the monthly gauge analysis is received
- “Final” satellite-gauge product ~2 months after the observation month.

Given the multiplicity of runs discussed here and below, it is key to IMERG maintainability and consistency that all of the runs will share a common code. We expect the different runs to be achieved with options programmed into the single system, even if PPS chooses to install separate instantiations of the code for each run.

The baseline is for the “Early” and “Late” estimates to be calibrated to the Final product with climatological coefficients that vary by month and location, while in the Final product the multi-

satellite estimates are adjusted so that they sum to the monthly satellite-gauge combination computed in IMERG following the TMPA. In all cases the output contains multiple fields that provide information on the input data, selected intermediate fields, and estimation quality.

Finally, it is planned that the Early and Late runs will be executed in the PPS Real Time (RT) processing system, which is keyed to rapid creation of results, while the Final run will be executed in the PPS Production processing system. Potentially, the Late run might need to be shifted from the RT to the Production processing system, and differences in latency between the two could affect that choice.

3.2.2 Reprocessing

Reprocessing is key to creating consistent archives of data for users. This is true for users of all three runs of IMERG, so all three will be reprocessed. On the other hand, only the Production processing system supports reprocessing. There is no problem for the Final run, since it is computed in Production, but Early and Late will be computed in the RT. This issue is resolved by installing a clone of the Early and Late systems (“Early Clone” and “Late Clone”) that are only invoked for reprocessing. In this case the selection of input data available to the Early run will be approximated by limiting the forward time span of data to the typical latency time (~3 hours) before the Early run time (currently 4 hours after observation time). For simplicity, this solution will be implemented by using Production input datasets. These choices raise the possibility that the Early Clone reprocessed results will contain a different selection of input data than the original Early, and that the input data from a particular sensor may be produced by slightly different algorithms in some cases. In the latter case we may need to institute climatological calibrations in the Early Clone that are different from those in the Early. Finally, if it is necessary to move the Late run to the production system (previous Section), then it would not be necessary to install a Late Clone in the production system.

Reprocessing for both the Early and Late runs will need to occur after reprocessing for the Final run to allow computation of climatological calibration coefficients for Early and Late to the Final monthly product (which has gauge information).

3.2.3 Rotating Calibration Files and Spin-Up Requirements

There are two calibrations that require routine rotating accumulators in IMERG. First, there is the primary calibration of precipitation products, which in the TRMM era is carried out as TMI calibrated to the TCI, and in the GPM era is carried out as GMI calibrated to the GCI. This calibration is done over an interval of 6 5-day periods (6 pentads) for stability. [Recall that the TMI and GMI products are used as calibrators for all the other satellite precipitation estimates. This is done because matchups between TCI or GCI with the other sensors are exceedingly sparse.] Note that TMI will take the status of just another (high quality) sensor during the period in which GMI is officially operating.

The second rotating accumulator is for the Kalman filter, whose statistics are currently calibrated over a 5-month period. It is a matter of study in Day-1 to determine whether this interval is necessary, or whether it could be shorter.

There are also a number of calibrations that are currently climatological, but have the potential to be converted to rotating calibration files after Day-1 if further research shows that the climatological approach is insufficiently accurate. These include the various calibrations of TMI

and GMI to other sensor precipitation datasets, and the calibration of the PERSIANN-CCS precipitation index to microwave data.

The rotating calibrations are necessarily trailing in the Early and Late runs, but we use a centered approach for the Final run. That is, the Early and Late calibrations are updated together with the computation of the precipitation, while the Final calibration is accumulated for an entire month, then the Final run will be executed for that month.

The final issue for the rotating accumulation files is providing seed and restart files. The development team provides the start-of-record seed files for TRMM and GPM. Thereafter, in normal operations the rotating files are programmed to refresh as new data arrive. However, it is likely that processing difficulties, bad input data, or undetected code errors will force a restart of processing. To accommodate this case, PPS saves daily dumps of rotating accumulation files and all the intermediate files.

3.3 INPUT DATA

3.3.1 Sensor Products

The sensor products are detailed in Section 2 as part of the discussion of the various sensors. For the most part, the datasets listed in Table 1 from previous and current sensors are already archived at PPS as part of the TMPA work under TRMM, but the requirement in GPM is that all inputs be processed using GPROF2014. As such, we will work closely with the developers at Colorado State Univ. and with PPS in Day-1 testing to ensure use of the best quality products.

3.3.2 Ancillary Products

The ancillary products required on a routine basis for the Day-1 IMERG algorithm are surface type, surface temperature, and surface relative humidity. Surface type is provided by the standard static map of percent water coverage from PPS. Surface temperature, relative humidity, and surface pressure are provided by the JMA GANAL forecasts (for Early) and gridded assimilation (for Late and Final) of meteorological data.

3.4 MICROWAVE INTERCALIBRATION

As in TRMM, the IMERG precipitation estimates are calibrated to the deemed highest-quality GPM single- or combined-sensor estimates following Huffman et al. (2007), currently the GCI estimates. During the initial release period in the GPM mission it is planned to use a short-record (6-9 month)-based calibrator until a longer GPM-based calibrator is available and reprocessing is done. The microwave intercalibration technique will be based on quantile-quantile matching, similar to Miller (1972) and Krajewski and Smith (1991). The temporal and spatial scale of the histogram matching for any given sensor will depend upon the unique orbit and individual sensor characteristics. Vastly different orbits, leading to fewer data overlaps, may require a longer calibration period to ensure representative geographic and diurnal sampling. Similarly, radically different sensors may require higher spatial and temporal resolution sampling. Climatological (fixed) calibrations are used when possible, with dynamically-computed (monthly, say) calibrations utilized when necessary. Comprehensive analysis in Day-1 will determine the exact nature of the calibration for each individual sensor's estimates.

CMORPH-KF, PERSIANN-CCS, and TMPA-RT all use various lengths of trailing calibration in which updating is considered necessary, and this is the intended approach for the real-time

IMERG runs. The post-real-time TMPA uses a calendar-month calibration, but for consistency in the Day-1 code we plan to routinely update the calibration such that each day is approximately in the middle of its calibration period. [This might be termed a “displaced trailing calibration.”]

One improvement in GPM over TRMM is that both DPR and GCI are available in real time, whereas PR and TCI are not in TRMM. This allows us to have the same calibrating sensor for all the runs.

3.5 MERGED MICROWAVE

The intercalibrated microwave precipitation estimates from GMI, TMI, and all of the partner sensors in the constellation are merged to create Level 3 data sets containing the best observational data available in each half hour. All of the input data sets are gridded from their native Level 2 swath data to the IMERG 0.1°x0.1° Level 3 global grid on the IMERG half-hourly interval (namely the first and second half hour for each UTC hour). The grid is populated with sensor data in the priority order conical-scan radiometer, and then cross-track scanner. If there is more than one sensor in a class, the one closer to the center of the half hour is chosen. The precipitation estimate, sensor type, and time of observation (to the nearest minute) are reported in the output data set.

3.6 MICROWAVE-CALIBRATED IR

Geo-satellites give frequent sampling, but the resulting IR Tb data are related to cloud top features (temperature and albedo) rather than directly to surface precipitation. This indirect relationship is best captured if the IR Tb-precipitation relationship is improved using texture and patch classification as well as applying routine updates using leo-PMW based precipitation estimates. Here, following the PERSIANN-CCS (Hong et al. 2004), the 60°N-S latitude belt is subsetted into 24 overlapping sub-regions (six in longitude by four in latitude) to allow for regional training and parallel processing. For each sub-region, the full-resolution IR Tb field is segmented into separable cloud patches using a watershed algorithm. Cloud patch features are extracted at three separate temperature levels: 220K, 235K, and 253K, which are chosen to demonstrate the existence of the cloud patches at different altitudes in the atmosphere. An unsupervised clustering analysis (Self-Organizing Feature Map) is used to classify cloud patches into a number of cloud patch groups based on the similarities of patch features. Precipitation is assigned to each classified cloud patch group based on a training set of leo-PMW precipitation samples. These initial precipitation estimates are then adjusted using coefficients based on a trailing backlog of matched leo-PMW precipitation and cloud-patch precipitation. The backlog is sized to ensure sufficient sampling to generate a stable estimate.

3.7 KALMAN-SMOOTHER TIME INTERPOLATION

Under the Kalman Smoother framework as developed in CMORPH-KF and applied here, the precipitation analysis for a grid box is defined in three steps (Joyce et al. 2011). First, PMW estimates of instantaneous rain rates closest to the target analysis time in both the forward and backward directions are propagated from their observation times to the analysis time using the cloud motion vectors computed from the geo-IR images (see next paragraph). The “prediction” of the precipitation analysis is then defined by compositing the forward- and backward-propagated PMW estimates with weights inversely proportional to their error variance. If the gap between the two PMW observations is longer than 90 minutes, the final “analysis” is defined

by updating the forecast with IR-based precipitation observations with weights inversely proportional to the observation error variance. This 90-minute threshold is due both to the natural timescale of precipitation at these fine scales and to the retrieval errors in the microwave algorithms.

The cloud motion vectors used to propagate the PMW estimates are calculated by computing the pattern correlation between spatially lagged geo-IR Tb arrays from two consecutive images. The spatial displacement with the highest correlation is used to define the cloud motion vector. The cloud motion vectors are defined for each 2.5° lat/lon grid box using IR data over a 5° lat/lon domain centered on the target grid box. Over mid-latitudes, precipitation systems present slightly different movements than the cloud systems that we are tracing with the geo-IR Tb. To account for the differences, the PDFs of the zonal and meridional components of the cloud motion vectors were compared against those of the precipitation systems observed by the Stage II radar over the contiguous U.S. (CONUS). A static correction table was then established for adjusting the geo-IR-based cloud motion vectors in both hemispheres' mid-latitudes to better represent precipitation motion. Interpolation in time, and then space is used to provide spatially complete propagation fields.

Errors for the individual satellite estimates are calculated by comparison against TMI/GMI estimates. Error functions for the TMI/GMI are taken to be the same as those for the AMSR-E, based on an early comparison against the Stage II radar observations over CONUS. Expressed in the form of correlation, the errors for the propagated PMW estimates are defined as regionally dependent and seasonally changing functions of sensor type (imager, sounder, IR) and the length of propagation time. Over land, the error functions are computed for each 10° latitude band using data collected over a 30°-wide latitude band centered on the target band. No zonal differences in the error are considered due to the limited sampling of the data. Over ocean, the error functions are defined for each 20°x20° lat/lon box using data over a 40°x40° lat/lon region centered on the target box. Over both land and ocean, the error functions are calculated for each month using data over a three-month period, trailing for Early and Late, and centered on the target month for Final, to account for the seasonal variations. The comparisons against Stage II were done once, while those against TMI/GMI are updated monthly.

3.8 SATELLITE-GAUGE COMBINATION

For the baseline post-real-time IMERG package, we will follow the TMPA approach for infusing monthly gauge information into the fine-scale precipitation estimates (Huffman et al. 2007). All of the full-resolution multi-satellite estimates in a month are summed to create a monthly multi-satellite-only field. This field is combined with the monthly GPCC precipitation gauge analysis (over land) in a two-step process. First, the multi-satellite estimate is adjusted to the large-scale bias of the gauges, and then the adjusted multi-satellite and gauge fields are combined using weighting by inverse estimated error variance. The satellite-gauge combination is a product in its own right. In addition, the field of ratios between the original multi-satellite and satellite-gauge fields is computed, then each field of multi-satellite precipitation estimates in the month is multiplied by the ratio field to create the final fine-time-resolution IMERG estimates.

3.9 POST-PROCESSING

The baseline IMERG real-time products will follow the TMPA procedure in providing both the original multi-satellite estimate and a climatologically calibrated field. The climatological

calibration is intended to make the real-time products as consistent as possible with the Final product. One important simplification compared to the TMPA is that both the DPR and GCI are computed in real time for GPM. This contrasts to the situation in TRMM where the PR and TCI are not computed in real time and we have had to substitute TMI as the RT calibrator. Accordingly, in GPM only a straightforward calibration to the Final product will be computed with a climatological GCI calibration. If the sub-monthly precipitation gauge combination option is incorporated in the Late product, presumably the need for post-processing will have to be re-assessed, but the Early product is certain to require the climatological calibration to the Final product.

3.10 PRECIPITATION PHASE

One recent request by users is to estimate the phase of the precipitation (i.e., liquid, solid, or mixed). None of the standard precipitation algorithms provide such information, so we must use ancillary data sets to create the estimate. Formally, there should be separate estimates for each phase. However, mixed-phase cases tend to be a small fraction of all cases, and we consider the estimation schemes to be sufficiently simplistic that estimating mixed phase as a separate class seems unnecessary. Most users appear to focus on the solid phase, both due to the delays it introduces in moving precipitation water mass through hydrological systems and due to the hazardous surface conditions that snow and ice create. Accordingly, we lump together liquid and mixed as “liquid” and compute a simple probability of liquid phase. For the half-hourly data, we adopt the Liu scheme (personal communication, 2013), which is under development for the Radiometer Team. The present (experimental) form is a simple look-up table for probability of liquid precipitation as a function of wet-bulb temperature, with separate curves for land and ocean. This is a current area of research in the field, so we anticipate changes as research results are reported. Since this diagnostic is independent of the estimated precipitation, we choose to report the probability of liquid phase for all grid boxes, including those with zero estimated precipitation.

At the monthly scale the probability could either be the fraction of the time that the precipitation is liquid or the fraction of the monthly accumulation that fell as liquid. The latter seems to be what most users will want, so this is the parameter computed. The monthly probability of liquid is the precipitation-rate-weighted average of all half-hourly probabilities in the month, except for grid boxes where zero precipitation is estimated for the month, in which case it is the simple average of all available probabilities in the month.

3.11 ERROR ESTIMATES

Error estimates are a required item in the output datasets. The baseline fine-scale datasets errors are estimated as part of the Kalman filter methodology. The baseline monthly Final dataset error estimates are computed as part of the optimal estimation of the satellite-gauge combination. It is possible that more sophisticated error fields can be incorporated as part of IMERG after Day-1, for example providing additional information on the error quantiles following Maggioni et al. (2014). In such a case, the critical problem is to limit the number of time/space-varying parameters that consequently require the insertion of additional parameter fields in each dataset.

3.12 ALGORITHM OUTPUT

All output data files have multiple fields with PMM-mandated metadata and are written in HDF5 v1.8, which is compatible with NetCDF4. The choice of fields varies, depending on which data run is creating the output. Table 3 contains the notional lists of data fields. Recall that PMM will provide an on-the-fly data subsetting by time, region, and parameter, so users are not required to download the entire file. Alternatively, PPS is considering providing two files for the half-hourly output, one “simple” file with precipitation alone and another “detail” file with the rest of the fields to reduce requests for the same ad hoc subsetting.

As listed in Table 2, the notional requirement is that the output be on a global 0.1° grid. However, there is a strong argument that a fully global grid should be (approximately) equal-area, and this issue is under discussion within the project for Day-2 products. Also, the IR data are actually available on a 0.035° grid, and the question has been raised whether the notional grid size ought to be 0.035°-0.05°. However, at present the baseline is left at 0.1° because there are scientific questions about downscaling microwave footprints to the finer scale, and operational questions about data volume.

Table 3. Lists of data field variable names and definitions to be included in each of the output datasets. Primary fields for users are in italics.

<i>Half-hourly data file (Early, Late, Final)</i>	
<i>precipitationCal</i>	<i>Instantaneous precipitation - calibrated</i>
precipitationUncal	Instantaneous precipitation - uncalibrated
<i>randomError</i>	<i>Precipitation random error</i>
HQprecipitation	PMW precipitation
HQprecipSource	PMW source identifier
HQobservationTime	PMW source time
IRprecipitation	IR precipitation
IRkalmanFilterWeight	IR KF weight
<i>probabilityLiquidPrecipitation</i>	<i>Probability of liquid precipitation phase</i>
<i>Monthly data file (Final)</i>	
<i>precipitation</i>	<i>Sat-Gauge precipitation</i>
<i>randomError</i>	<i>Sat-Gauge precipitation random error</i>
gaugeRelativeWeight	Gauge relative weighting
<i>probabilityLiquidPrecipitation</i>	<i>Accumulation-weighted probability of liquid precipitation phase</i>

3.13 PRE-PLANNED PRODUCT IMPROVEMENTS

Throughout the useful life of the Day-1 IMERG we plan for the code to be reasonably robust to errors, drop-outs, and changes in the make-up of the satellite constellation. The preceding discussion also detailed some developmental issues that can only be addressed once IMERG is running. In addition, the team considers it helpful to pre-plan certain enhancements to the code that we are fairly certain will be required at some point.

3.13.1 Addition/Deletion of Input Data

Satellites come and go over time. For the most part, satellite drop-outs, other than of the GPM Core itself, simply result in a smaller amount of input data for the system. Addition of data, on the other hand, is potentially complicated by a range of possible priorities and calibration needs of the new sensor. In IMERG we follow the work pioneered in the Version 7 TMPA, where extra satellite slots are programmed in, separated into conical scanners and sounders. When a new sensor comes on-line, it can be assigned to an appropriate-type slot and start contributing from that point forward, once the calibration coefficients are determined, which can require several months of data. However, including the new sensor's data from before the date/time on which it is instituted in the dataset requires reprocessing (next Subsection).

3.13.2 Upgrades to Input Data

When an existing sensor's data record is reprocessed, or a new sensor is introduced that has an archive not previously used, it is necessary to reprocess the archive of IMERG data to preserve consistent statistical behavior (to the extent possible) across the entire record. While reprocessing should not be undertaken lightly, given the computing demands on PPS and the disruption to the users, hard practical experience shows that we need to be more aggressive about this issue than has been the case previously for the TMPA. For example, the second version of NESDIS AMSU, introduced in 2004, resulted in an underestimate of light rain. The result in the TMPA during part of Version 6 was a low bias in fractional coverage and rain amount over ocean. When an upgraded version of the NESDIS AMSU was introduced in early 2007 these biases were greatly reduced, but we allowed the inhomogeneity to persist in the Version 6 TMPA archive. As a result, users had to be continually reminded that the relatively low values are a known problem, a problem that was not fixed until the Version 7 reprocessing some five years later.

3.13.3 Polar Sensors

The Multi-Satellite team intends to extend IMERG to the polar regions, consistent with GPM's fully global focus. This requires estimating displacement vectors at higher latitudes from the asynchronous assemblage of leo-IR satellites. We will then use these vectors to displace the available high-latitude precipitation estimates and apply the backward/forward Kalman filter to compute the output estimates. Available high-latitude estimates include the TOVS and AIRS estimates computed using the Susskind et al. (1997) algorithm, AMSU and MHS estimates computed by Surussavadee and Staelin (2008a,b) and recently prototyped in NOAA/STAR (Meng et al. 2012), and numerical model estimates (Subsection 3.12.5). This development work will require close cooperation with the experts in high-latitude GV.

3.13.4 Upgrades for RT

It is likely that the RT will require modifications to create the most useful output. For example, it might be necessary to tune the latency of the Early and/or Late runs to accommodate the realities of the data reception. Tuning for the Late run will also have to balance the useful time range of backward-propagated microwave data against the latency of the following microwave overpass. In addition, work to improve the calibration of the RT to the Final post-real-time production dataset might require a reprocessing to implement the improvement. If the daily gauge option is instituted for the Late run, we believe we can fit it into the latency structure of the baseline scenario. That is, if the daily gauge analysis has a latency that is much longer than

the Late run satellites require, the daily gauge computation might be able to use the PDF of data up through the previous day.

3.13.5 Use of Model Estimates

Validation work by Ebert et al. (2007) among others, demonstrates that numerical model estimates of precipitation can out-perform observational estimates at daily $0.25^\circ \times 0.25^\circ$ scale in the cool season over land. This stands in contrast to the poor performance by model estimates in tropical and subtropical conditions for day-to-day variations, diurnal cycle, and seasonal variation. The Multi-Satellite team's experience in isolating bias in input datasets and the flexible, error-sensitive behavior of the Kalman filter concept seem to suggest that IMERG is a natural platform for testing the joint use of observational and model-base precipitation estimates. This is particularly true given the expectation that the team will be exploring extension into polar regions (Subsection 3.12.3). It is absolutely clear that the team intends to maintain a robust observation-only capability throughout GPM to support a variety of applications, not the least being validation of model estimates. However, a parallel joint observation-model product is a worthy contribution to the project and to advancing scientific understanding.

3.14 OPTIONS FOR PROCESSING

Since the clear mandate for the Day-1 algorithm has been driven by a very aggressive schedule (ATBD, working code, and final code in November of 2010, 2011, and 2012, respectively), the baseline algorithm described in this Subsection is designed around code that was already running and tested. At the same time, the team has several concepts in research that might become sufficiently mature that one or more of them might be prime targets for upgrading the Day-2 version.

3.14.1 Use of Multi-Spectral Geo-Data

Besides the thermal IR channel discussed above, geo-satellites also provide other channels, usually visible and one or more spread across the IR spectrum. Historically, these channels have not been used due to apparent modest improvements in skill, difficulties in handling the higher data volumes, and limitations to daylight hours (for visible). However, our ongoing dependence on geo-satellite data to fill large gaps between PMW overpasses and the increasing number of channels on newer satellites make it important to reconsider this aspect. Recent studies seem to indicate reasonable increases in skill using modern neural net approaches, particularly when visible data are used (Behrangi et al. 2009). Several important steps must be taken to capitalize on this apparent benefit in using multi-spectral data. First the scientific development must be advanced to operational status. Second, we must work with the data providers to arrange for routine delivery of the data in a useful format, including a complete archive. Third, choices must be made on the selection of channels, recognizing that previous generations of geo-satellites had less-capable sensors than those now appearing.

3.14.2 Computing Propagation from Precipitation

The propagation vectors currently used in the CMORPH-KF Lagrangian time interpolation are computed from IR-based cloud motions. As noted in Subsection 3.6, these differ from the motion of precipitation systems, creating a source of error. Accordingly, the team expects to work on alternative schemes to more accurately estimate motion from precipitation data.

3.14.3 Incorporating Cloud Development Information

Precipitation develops and decays over time periods that are short compared to the typical revisit time of the leo-PMW constellation. Experience shows that the correlation of observed and propagated precipitation fields may drop from 1.0 to ~0.6 within 30 minutes and further fall to ~0.4 or lower after an hour of propagation. Instantaneous geo-IR precipitation estimates are notoriously poor, but nonetheless provide a minimum floor of skill when a gridbox lacks recent propagated leo-PMW estimates. Taking a different approach, capturing the dynamic evolution of geo-IR cloud images may help to identify cloud systems in various stages of development. This approach to addressing the “cloud development problem” is a relatively new area of research and requires further investigation to determine the best strategies for capturing the development process. One possibility is to drive a highly simplified conceptual cloud model with parameters computed from the geo-IR Tb data, as in the Bellerby et al. (2009) Lagrangian Model (LMODEL). Another is to modify the propagated leo-PMW precipitation estimates with time based on parameters computed from the geo-IR Tb data, as in the Behrangi et al. (2010) Rain Estimation using Forward Adjusted-advection of Microwave Estimates (REFAME).

3.14.4 Use of Daily Gauges

The biases discussed previously vary on sub-monthly time scales, of course. To address this problem, we will examine the possibility of refining the bias correction approach described in Subsection 3.7 through the use of daily gauge analysis. Recently, CPC has developed a new technique to correct the bias in high-resolution satellite precipitation estimates through matching the PDF of the satellite estimates against that of the daily gauge analysis (Xie et al. 2010). The PDF bias correction is carried out in two steps using historical, and then real-time data. First, PDF tables are constructed for each 0.25° lat/lon gridbox over the global land and for each calendar day using co-located satellite and gauge data pairs over a spatial domain centered on the target grid box and over a sliding window of 31 days centered on the target calendar day for the 16-year period from 1998 to the present. The spatial domain is expanded until a sufficient number of data pairs are collected. After the correction using historical data, the satellite estimates are further calibrated against the real-time data to remove the year-to-year variations in the bias. To this end, PDF tables are created using co-located data collected over a 30-day period ending at the target date. The least numbers of co-located data pairs used to create PDFs are 500 and 300 for the corrections using historical and real-time data, respectively.

4. TESTING

The CMORPH-KF and PERSIANN-CCS systems were brought up in the GSFC development environment in GSFC Code 612 with the minimum number of changes possible to ensure that the code as originally presented was functional. The TMPA code already satisfied this requirement. Thereafter, the IMERG code was the development system.

4.1 ALGORITHM VERIFICATION IN THE PPS SYSTEM

As the baseline IMERG code has been developed it has been validated on the development system. At the agreed-upon deliveries the entire package was assembled and transferred to PPS for integration and testing. The first “production” tests are being carried out in the PPS Operational Acceptance Test process in parallel with the then-current TMPA processing. This

allows us to make detailed and summary comparisons between the two sets of products. The new IMERG products are being compared against coincident CMORPH-KF, PERSIANN-CCS, and TMPA fields. The goal in this stage is to shake out as many bugs and conceptual difficulties as possible, applying corrections to the production and real-time IMERG instantiations.

4.2 ALGORITHM VERIFICATION FOR THE DIFFERENT RUNS

The main features to be validated between the real-time and production instantiations are the use of somewhat different input data sets and the addition of monthly gauge calibration in the Final run. As before, it is important to compare the results to the other estimates and validation data listed above.

4.3 ALGORITHM VALIDATION

The more formal algorithm validation will examine various aspects of the IMERG results. At the snapshot level, comparison to the fine-scale NOAA Next-Generation Multi-Sensor Quantitative Precipitation Estimates (Q2), and to the PMM Kwajalein and Melbourne radar archives are considered key. As part of this effort, we are carrying out similar comparisons against the gridded Level 2 input data. The performance at larger space-time scales will be assessed using accumulations of these three datasets, as well as the CPC daily gauge analysis, the IPWG validation sites (Australia, CONUS, Japan, South America, Western Europe), the GPCC global monthly gauge analysis, the Pacific atoll data, and the ATLAS II buoy data. For higher-latitude validation, the GPCC data can be used to validate the satellite-only products. The team already has access to Finnish Meteorological Institute precipitation gauge data, and will work with the P. Groisman project to access precipitation gauge data and metadata over much of the high-latitude Northern Hemisphere. At a minimum, metrics should include bias, root-mean-square error, mean absolute error, correlation, and skill scores. Decompositions into hit error, miss error, etc. following Tian et al. (2009) should be considered as well. We will invite the validation teams, such as the W. Krajewski project, to examine the test datasets with the detailed validation approaches that they are developing. Finally, we will invite selected users, particularly hydrologists, to use the test datasets and report their experiences to help determine what IMERG's level of skill is for their applications. Ideally, the PMM Ground Validation (GV) team will establish an ongoing monitoring activity to detect dataset quality problems.

5. PRACTICAL CONSIDERATIONS

5.1 MODULE DEPENDENCIES

The baseline structure of IMERG is shown in Fig. 2. We have not enforced consistency on the various boxes in the sense that some boxes might be programmed as multiple modules, while others will be computed in a single module. As summarized in Subsection 5.2, the data flow between modules, and between executions of the same module, is carried out using files, which typically have fixed names. Input and output datasets necessarily have names that reflect the time sequencing of the data that they contain.

The satellite-satellite calibrations, which include the PMW intercalibrations to a GPM standard (block 2), IR-PMW precip calibration for the IR estimates (block 10), and the Kalman filter weights (block 7), are conceptually asynchronous with the actual half-hourly precipitation

dataset processing. It is a matter for discussion with PPS as to whether the calibrations will be run sequentially or in parallel, but the system is designed to be very forgiving of occasional missed calibration match-ups – without significant loss of skill it can run with the then-current calibration files, as long as the dropouts do not become too severe. The heritage TMPA system has computed the PMW intercalibration on a calendar month basis, while the PERSIANN-CCS and CMORPH-KF have run the IR-PMW and KF weights, respectively, on trailing accumulations of match-ups. For IMERG we plan to run all the Early and Late calibrations on trailing accumulations of match-ups. In the case of the post-real-time Final analysis, we must wait for the GPCC precipitation gauge analysis, so we plan to accumulate the match-ups with a sufficient delay after real time that the Final calibrations are approximately centered.

The only important difference between real- and post-real-time runs comes in the last calibration, which will be computed for the real-time as climatological adjustments to the Final product, and for the post-real-time as calendar-month adjustments to, and combination with monthly gauge analyses. It is a matter for discussion with PPS as to how far the “Final” processing will be carried through the system pending the delivery of the monthly precipitation gauge analysis about two months after the end of the month.

As noted above, we plan to compute three runs of the algorithm, namely the “Early”, “Late”, and “Final” runs at about 4 hr, 12 hr, and 2 months after observation time. The simplest approach is chosen, namely to maintain three entirely separate sets of files and to compute everything in each run. This eliminates dependencies between runs and facilitates retrospective processing.

5.2 FILES USED IN IMERG

Input, output, inter-module data transfer, and inter-run/static data storage is accomplished through files in IMERG. Table 4 displays our best estimate of what the file sizes and count might be, but as input files come into focus these numbers will certainly change. Also, it is important to note that the granularity of the input data implies that two of each of the input types will have to be used in each half-hour with fair regularity. On the other hand, the precipitation gauge analysis provides only one file in a month, which is also true for the monthly Merged Satellite/Gauge product. Several of the options and planned upgrades will require the use, transport, and accumulation of data in additional files.

5.3 BUILT-IN QUALITY ASSURANCE AND DIAGNOSTICS

To the extent possible, every effort is being made to incorporate quality assurance checks in the IMERG system. This includes quality checks of all input data, and of selected intermediate and output data based on metrics developed for TRMM. The goal of these metrics is to capture discrepancies before they propagate into the downstream processing. PPS toolkit warning and error messages are the primary mechanism used to flag potential problems. Optional diagnostic information are available to the operator when requested. It is possible that a separate, post-processing algorithm will be used to extend the quality assurance procedure to the Final product as part of the Day-1 operational development. The goal of this post-processing algorithm is to capture more subtle issues than observable during production.

5.4 SURFACE TEMPERATURE, RELATIVE HUMIDITY, AND PRESSURE DATA

The estimation of precipitation phase requires global surface temperature, relative humidity, and pressure data, since the operational algorithms cannot provide phase directly. The JMA model forecast data are computed in 6-hour increments, and five 6-hour increments are provided within a single delivered file (i.e., a day). The data are provided in grib2 format, and will be converted to individual 6-hour files in flat binary by PPS using the standard wgrib2 utility. This binary file is read into IMERG and the appropriate parameters extracted and used to compute the percent probability of liquid phase.

Table 4. Estimates of file counts and sizes to be used in IMERG. The letters i, o, t, a, s in “Module Relation” indicate input, output, transfer (between modules or within a module), accumulator, and static, respectively. The numbers in “Module Relation” are keyed to the numbered boxes in Fig. 2. M-T MADRAS is not included in this list due to its short, gappy record.

<i>INPUT</i>					
<i>ID</i>	<i># Granules</i>	<i>Granularity</i>	<i>Granule Size (MB)</i>	<i>Total Size (MB)</i>	<i>Module Relation</i>
AIRS	1	One orbit	11	11	i2
AMSR x 2	2	One orbit	56	112	i2
AMSU x 3	3	One orbit	56	168	i2
ATMS x 2	2	One orbit	56	112	i2
CrIS	1	One orbit	11	11	i2,i4
GCI	1	One orbit	328	328	i2
GMI	1	One orbit	56	56	i2
GPCC	1	One month	8	8	i11
IR	2	One hour	65	130	i1,t1-4,t1-8
JMA Forecast Tsfc, RHsfc, Psfc	1	forecast run	121	121	i11,i12
JMA Analysis Tsfc, RHsfc, Psfc	1	analysis run	120	120	i11,i12
MHS x 6	6	One orbit	56	336	i2
SAPHIR	1	One orbit	56	56	i2
SSMI x 3	3	One orbit	56	168	i2
SSMIS x 4	4	One orbit	56	224	i2
TCI	1	One orbit	328	328	i2
TMI	1	One orbit	56	56	i2
TOVS	1	One orbit	11	11	i2

<i>INTERMEDIATE/STATIC</i>				
<i>ID</i>	<i># Files</i>	<i>Size (MB)</i>	<i>Total Size (MB)</i>	<i>Module Relation</i>
GCI-GMI accum	1	1385	1385	a2
GMI-other cal	21	25	525	s2
Surface type	1	52	52	s2
TCI-TMI accum	1	1385	1385	a2
TMI-other cal	21	25	525	s2

Table 4, cont.

<i>TRANSFER</i>					
<i>ID</i>	<i># Granules</i>	<i>Granularity</i>	<i>Granule Size (MB)</i>	<i>Total Size (MB)</i>	<i>Module Relation</i>
Gridded HQ	14*	One orbit	103	1442	t2
TCI-TMI cal	1	One orbit	259	259	t2
GCI-GMI cal	1	One orbit	259	259	t2
Cloud Motion Vectors	2	One hour	0.2	0.4	t4,t4-6
Kalman Filter weights	1	One month	290	290	t6-7
PMW	2	30 minutes	103	206	t2-5,t2-5,t2-9
PMW forward and backward prop	2	30 minutes	103	206	t5-7
Intermediate IR	1	30 minutes	65	65	t8
Intermediate HQ	1	30 minutes	103	103	t9
IR sub areas	1	30 minutes	79	79	t8
CCS precip sub areas (unadjusted)	1	30 minutes	54	54	t8-10
CCS precip sub areas (adjusted)	1	30 minutes	54	54	t10
Cloud classification	48	30 minutes	0.4	19.2	s8
IR/rainrate	48	30 minutes	14	168	s8
CCS global precip (adjusted)	1	30 minutes	54	54	t10-6,t10-7
Merged PMW/IR (uncal)	1	30 minutes	103	103	t7-11,t7-12

* Although 31 sources of “high-quality” satellite data are listed under “INPUT”, it is assumed that no more than 14 such satellites will be available at any given time.

<i>OUTPUT</i>					
<i>ID</i>	<i># Granules</i>	<i>Granularity</i>	<i>Granule Size (MB)</i>	<i>Total Size (MB)</i>	<i>Module Relation</i>
Merged MW/IR (cal)	1	30 minutes	181	181	o11,o12
Merged MW/IR	1	One month	58	58	o11

5.5 EXCEPTION HANDLING

Like the TMPA predecessor, the IMERG system is quite robust in handling exceptions, including input file existence and integrity, command-line consistency, and routine data checks. The algorithm developers are working with PPS to specify a minimum set of required inputs for each algorithm, and the conditions under which the IMERG system should report issues using the PPS toolkit. It is the responsibility of the Multi-Satellite Team to create and update the toolkit error messages. When issues are flagged by the toolkit, additional diagnostic output is integrated into the code by the developers to assist in isolating the problem when requested by the operator. Error reporting is used when exceptions are significant enough to halt execution. Warning reporting is used when exceptions should be noted, but processing can continue. In

both cases, PPS will contact the algorithm developers to determine the severity of the exception and how best to address it.

5.6 TRANSITIONING FROM TRMM- TO GPM-BASED PRODUCTS

During the start-up testing described in Section 4, we favor providing routinely computed IMERG products to successively more users as soon as practical in order to 1) gain critical feedback from key user groups as early as possible, and 2) give users the maximum time possible to make the transition to the new processing paradigm. This should occur in Q4 2014, clearly using a short (6-9 month) GPM record as the calibrator to generate “GPM proxy” products. It is open for discussion whether we can run and disseminate the legacy TMPA and the new IMERG products in full parallel, or whether the project will consider one to be an off-line product. The first multi-year archive of IMERG RT will be created in Q1 2016.

This nominal scenario assumed that TRMM persists (currently forecast to last into 2016) and provides data until the acceptance of GPM. Since TRMM has exhausted its fuel the legacy TMPA-RT actually uses climatological TRMM-based RT calibrations, so the only actual effect is the loss of the TMI precipitation estimates in the combined microwave field. The impact on the final TMPA and all IMERG fields is more serious, since they routinely used the TCI product as a calibrator. We are implementing a “fail-safe” climatological calibration and accepting the lower quality result in order to maintain continuity.

5.6 TIMING OF REPROCESSING FOR IMERG PRODUCTS

As hinted in the previous Subsection, the decision to reprocess the production IMERG archive as the result of algorithm changes in one or more input products critically depends on the availability of a completely reprocessed archive of the affected input product(s). In particular, when a general reprocessing is called for in the GPM suite of products, the IMERG products can be started only after the requisite Level 2 GPM products have been finalized and substantially reprocessed, allowing IMERG to apply the upgraded data for calibration and routine use in the products. Furthermore, such a general reprocessing probably implies the need to update the IMERG RT products and a consequent need to reprocess the IMERG RT archives as well.

6. ASSUMPTIONS AND LIMITATIONS

6.1 DATA DELIVERY

In general, the IMERG package is extremely forgiving of dropouts in individual sensors, including the calibrating sensor products and the geo-IR data. Our experience with the TMPA is that extended drop-outs are rare for the TMI and PR (and so TCI). When the PR anomaly occurred in late June 2009, we completed the TMPA for June, then held production. Eventually, roughly 15 days of PR was declared missing, so we instituted a manual process to create calibrations that covered 30 days of data that adjoined the missing period. The TMPA-RT was unaffected, since the calibrations are climatological, as explained above. Extended geo-IR dropouts in the TMPA-RT have been back-filled as a service to users, but this is not required to enable continued RT production.

6.2 ASSUMED SENSOR PERFORMANCE

The implicit assumption in the IMERG code is that the various PMW datasets are either stable or unavailable. The main impact of data denial is on IMERG quality. There is a time-dependent calibration update for the PMW-IR calibration in both real and post-real time, and for the calibration of GMI to GCI in the post-real-time. So, if the IR is drifting, the time-dependent calibrations should account for the problem. However, assuming that we use climatological GMI-to-everything-else calibrations in the RT products, a drifting GMI cannot be accommodated. We would be more flexible if we decide to routinely update these GMI-to-everything-else calibrations, since drift in the GMI would be automatically accommodated. For all sensors, including geo-IR and gauge, variations in the amount of unbiased noise should not automatically bias the results, although the resulting random errors will fluctuate correspondingly.

7. REFERENCES

- Adler, R.F., G.J. Huffman, A. Chang, R. Ferraro, P. Xie, J. Janowiak, B. Rudolf, U. Schneider, S. Curtis, D. Bolvin, A. Gruber, J. Susskind, P. Arkin, E.J. Nelkin, 2003: The Version 2 Global Precipitation Climatology Project (GPCP) Monthly Precipitation Analysis (1979-Present). *J. Hydrometeor.*, **4**(6), 1147-1167.
- Behrangi, A., K. Hsu, B. Imam, S. Sorooshian, G.J. Huffman, R.J. Kuligowski, 2009: PERSIANN-MSA: A Precipitation Estimation Method from Satellite-based Multi-spectral Analysis. *J. Hydrometeor.*, **10**(6), 1414-1429.
- Behrangi, A., B. Imam, K. Hsu, S. Sorooshian, T.J. Bellerby, G.J. Huffman, 2010: REFAME: Rain Estimation Using Forward Adjusted-Advection of Microwave Estimates. *J. Hydrometeor.*, **11**, 1305-1321.
- Bellerby, T., K. Hsu, S. Sorooshian, 2009: LMODEL: A Satellite Precipitation Methodology Using Cloud Development Modeling. Part I: Algorithm Construction and Calibration. *J. Hydrometeor.*, **10**, 1081-1095.
- Ebert, E.E., J.E. Janowiak, C. Kidd, 2007: Comparison of Near-Real-Time Precipitation Estimates from Satellite Observations and Numerical Models. *Bull. Amer. Meteor. Soc.*, **88**, 47-64.
- Hong, K.L. Hsu, S. Sorooshian, X. Gao, 2004: Precipitation Estimation from Remotely Sensed Imagery Using an Artificial Neural Network Cloud Classification System. *J. Appl. Meteorol.* **43**, 1834-1852.
- Huffman, G.J., R.F. Adler, D.T. Bolvin, G. Gu, E.J. Nelkin, K.P. Bowman, Y. Hong, E.F. Stocker, D.B. Wolff, 2007: The TRMM Multi-satellite Precipitation Analysis: Quasi-Global, Multi-Year, Combined-Sensor Precipitation Estimates at Fine Scale. *J. Hydrometeor.*, **8**(1), 38-55.
- Huffman, G.J., R.F. Adler, M. Morrissey, D.T. Bolvin, S. Curtis, R. Joyce, B. McGavock, J. Susskind, 2001: Global Precipitation at One-Degree Daily Resolution from Multi-Satellite Observations. *J. Hydrometeor.*, **2**(1), 36-50.
- Joyce, R.J., P. Xie, J.E. Janowiak, 2011: Kalman Filter Based CMORPH. *J. Hydrometeor.*, **12**, doi:10.1175/JHM-D-11-022.1, 1547-1563.
- Krajewski, W.F., J.A. Smith, 1991: On the Estimation of Climatological Z-R Relationships. *J. Appl. Meteor.*, **30**, 1436-1445.
- Maggioni, V., M.R.P. Sapiano, R.F. Adler, Y. Tian, G.J. Huffman, 2013: An Error Model for

- Uncertainty Quantification in High-Time Resolution Precipitation Products. *J. Hydrometeor.*, **15**(3), doi:10.1175/JHM-D-13-0112.1, 1274-1292.,
- Meng, H., B. Yan, R. Ferraro, C. Kongoli, 2012: Snowfall Rate Retrieval Using Passive Microwave Measurements. 12th Specialist Meeting on Microwave Radiometry and Remote Sensing of the Environment, 5-9 March 2012, Frascati, Italy.
- Miller, J.R., 1972: A Climatological Z-R Relationship for Convective Storms in the Northern Great Plains. *15th Conf. on Radar Meteor.*, 153-154.
- Rudolf, B., U. Schneider, 2005: Calculation of Gridded Precipitation Data for the Global Land-Surface Using In-Situ Gauge Observations. *Proc. of the 2nd Internat. Precip. Working Group Workshop*, 25-28 October 2004, Monterey, CA, 231-247.
- Schneider, U., T. Fuchs, A. Meyer-Christoffer, B. Rudolf, 2008: Global Precipitation Analysis Products of the GPCC. GPCC Internet Publication, DWD, 12 pp. Available online at ftp://ftp262-anon.dwd.de/pub/data/gpcc/PDF/GPCC_intro_products_2008.pdf.
- Surussavadee, C., D.H. Staelin, 2008: Global Millimeter-Wave Precipitation Retrievals Trained with a Cloud-Resolving Numerical Weather Prediction Model, Part I: Retrieval Design. *IEEE Trans. on Geosci. and Rem. Sens.*, **46**, 99-108.
- Surussavadee, C., D.H. Staelin, 2008: Global Millimeter-Wave Precipitation Retrievals Trained with a Cloud-Resolving Numerical Weather Prediction Model, Part II: Performance Evaluation. *IEEE Trans. on Geosci. and Rem. Sens.*, **46**, 109-118.
- Susskind, J., P. Piraino, L. Rokke, L. Iredell, A. Mehta, 1997: Characteristics of the TOVS Pathfinder Path A dataset. *Bull. Amer. Meteor. Soc.*, **78**, 1449–1472.
- Tian, Y., C. Peters-Lidard, J. Eylander, R. Joyce, G. Huffman, R. Adler, K.-L. Hsu, F. J. Turk, M. Garcia, J. Zeng, 2009: Component Analysis of Errors in Satellite-Based Precipitation Estimates. *J. Geophys. Res. - Atmos.*, **114**, D22104, doi:10.1029/2009JD011949.
- Villarini, G., P.V. Mandapaka W.F. Krajewski, R.J. Moore, 2008: Rainfall and Sampling Errors: A Rain Gauge Perspective. *J. Geophys. Res.*, **113**, D11102, doi:10.1029/2007JD009214.
- Xie, P., S.-H. Yoo, R. Joyce, Y. Yarosh, 2010: A High-Resolution Gauge-Satellite Merged Global Precipitation Analysis and Its Applications for Model Verifications. *WMO 3rd Internat. Conf. on QPE / QPF and Hydrol.*, 18-22 October, 2010, Nanjing, China.

8. ACRONYMS

AIRS	Advanced Infrared Sounder
AMSR-E	Advanced Microwave Scanning Radiometer – Earth Observing System
ATBD	Algorithm Theoretical Basis Document
ATLAS	Autonomous Temperature Line Acquisition System
ATMS	Advanced Technology Microwave Sounder
CLIMAT	Monthly Climatological Data
CMORPH-KF	CPC Morphing – Kalman Filter technique
CONUS	contiguous U.S.
CPC	Climate Prediction Center
CPO	Climate Program Office
CrIS	Cross-track Infrared Sounder
CRU	Climate Research Unit
DISC	Data and Information Services Center
DMSP	Defense Meteorological Satellite Program
DPR	Dual-frequency Precipitation Radar

DWD	Deutscher Wetterdienst
DWSS	Defense Weather Satellite System
EUMETSAT	European organization for the exploitation of Meteorological Satellites
FAO	Food and Agriculture Organization
GCI	GPM Combined Instrument product
GCOMW	Global Change Observation Mission - Water
geo	geosynchronous Earth orbit
GESDISC	Goddard Earth Science Data and Information System Center
GIOVANNI	Geospatial Interactive Online Visualization ANd aNalysis Infrastructure
GEWEX	Global Energy and Water cycle Experiment
GHCN	Global Historical Climatology Network
GMI	GPM Microwave Imager
GMS	Geosynchronous Meteorological Satellite
GOES	Geosynchronous Operational Environmental Satellite
GPCC	Global Precipitation Climatology Centre
GPCP	Global Precipitation Climatology Project
GPM	Global Precipitation Measurement mission
GSFC	Goddard Space Flight Center
HDF	Hierarchical Data Format
IMERG	Integrated Multi-satellitE Retrievals for GPM
IR	Infrared
JMA	Japanese Meteorological Agency
JPSS	Joint Polar Satellite System
KF	Kalman filter version
leo	low Earth orbit
LMODEL	Lagrangian Model
LT	Local Time
MADRAS	Microwave Analysis and Detection of Rain and Atmospheric Structures
Meteosat	Meteorological Satellite
METOP	Meteorological Polar Orbit satellite
MHS	Microwave Humidity Sounder
MTSat	Multi-functional Transport Satellite
NASA	National Aeronautics and Space Administration
NCDC	National Climatic Data Center
NESDIS	National Environmental Satellite Data and Information Service
NetCDF	Network Common Data Format
NOAA	National Oceanic and Atmospheric Administration
NPP	National Polar Operational Environmental Satellite System (NPOESS) Preparatory Project
PDF	Probability Density Function
PERSIANN-CCS	Precipitation Estimation from Remotely Sensed Information using Artificial Neural Networks – Cloud Classification System
PMM	Precipitation Measurement Missions
PMW	Passive Microwave
PPS	Precipitation Processing System
PR	Precipitation Radar

Q2	Next-Generation Multi-Sensor Quantitative Precipitation Estimates
REFAME	Rain Estimation using Forward Adjusted-advection of Microwave Estimates
RT	Real Time
SSMI	Special Sensor Microwave Imager
SSMIS	Special Sensor Microwave Imager/Sounder
SYNOP	Synoptic Weather Report
TCI	TRMM Combined Instrument product
TMI	TRMM Microwave Imager
TMPA	TRMM Multi-satellite Precipitation Analysis
TOVS	Television-Infrared Observation Satellite (TIROS) Operational Vertical Sounder
TRMM	Tropical Rainfall Measuring Mission
USWRP	U.S. Weather Research Program
UTC	Universal Coordinated Time